

RFCase

Coding, Marking or Labeling System

The RF Case offers the ideal solution for the automatic feeding of outer case packaging in their flat-form. This feeder has been designed to handle a range of outer case secondary packaging - it's twin conveyor design allows for the easy separation of boxes onto the conveyor, so they can be individually printed or labeled, ready for operator removal.

- Twin conveyor design to separate boxes
- Modular framework design
- Easily adjustable for different sized boxes
- Fixed speed drive (preset value can be changed)
- Min 200 x 200 x 3mm, Max 700 x 500mm product size (special mods available to max width & length)
- Electrical requirements 110 or 240V, 50 or 60 Hz. Single Phase, 2 amp.

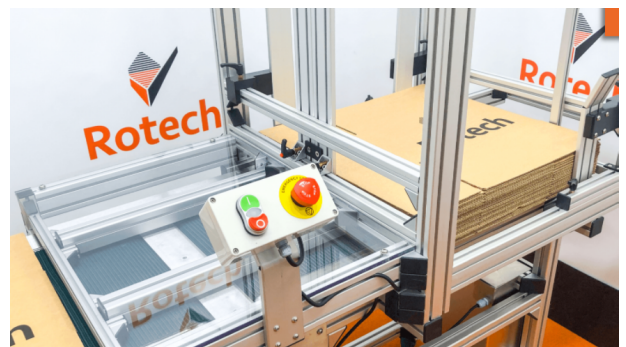

RFCase | Versatile Coding, Marking or Labeling System

The RF Case is ideally suited for feeding flat outer cases or boxes that need to be either labeled or printed off line. To accommodate this thicker type of typically corrugated product, the machine has a flat bed consisting of two conveyors that run at slightly different speeds so that a gap is created, thus permitting reliable product detection. Many different types of printer, labeler and even cameras can be fitted.

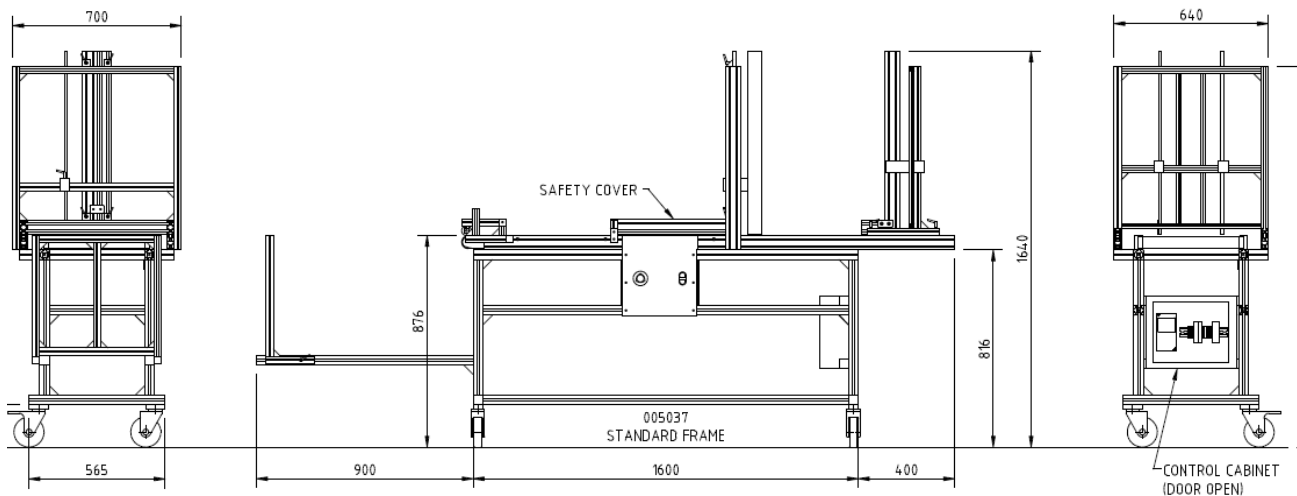

Other Benefits

- Modular design allows for expanded versions of the RF Case to suit larger products or printing processes requiring a longer conveyor
- Easily adjustable for different sized boxes

More Information

System	(L x W x H) 2020 x 530 x 1575mm (875mm to top of conveyor)
Product Size	Min 200 x 200mm, Max 700 x 500mm
Weight	120kg (265lb)

Printer Integration

- Compatible with a wide range of coding, marking and labeling technologies as well as post-print inspection systems
- Integration with HP or Seiko print systems to code high-resolution codes including alphanumeric text, graphics, barcodes, nutrition panels and more

