

**Markoprint**

HIGH QUALITY MADE IN GERMANY



# Integra Quadro

## Highspeed controller for up to 4 inkjet printhead

The new Markoprint Integra Quadro print controller controls up to four inkjet printers at up to four printing positions simultaneously or alternately. For instance, it enables printing primary and secondary packaging on both sides on one or two independent production conveyors, even using two different printing technologies (HP, Trident, Funai, Xaar or Seiko). The compact Markoprint Integra Quadro copes very well in confined spaces. The mounting options make installation easy within or directly at the production line. It was developed specially for integration in control cabinets and machines enclosures

Printing of barcodes, text, numbers, symbols and 2D codes using the inkjet printer has never been faster: Printing speeds of up to 240 m/min. at 300 dpi are achieved, depending on content to be printed and printing technology used. The proven, intuitive control panel enables convenient adjustment of printing and label settings in situ. The high-performance Markoprint iDesign software is used for creating and controlling the print layout. The Markoprint Integra Quadro has all conventional interfaces such as Ethernet and USB for 1:1 data transmission to the printheads and real time printing without batch processing.

## Advantages

- Compact design adapted to system integration
- Cap rail clip for control cabinet installation
- Setting adjustments directly at the controller
- Mounting elements on the print controller, for easy installation within or directly at production lines and in control cabinets
- Control of 4 printheads
- Use of 2 different technologies (up to 2 printheads per printing technology)
- Simultaneously operating on 2 lines (up to 2 printheads per production line)

Performance data	Advanced Version	Pro/HiSpeed Version
Maximum printing speed		
HP (Hewlett Packard) at 300dpi	90 m/min	180 m/min
LX (Lexmark) at 300dpi	60 m/min	240 m/min
MX (Trident) at 200 dpi	60 m/min	60 m/min
XR (Xaar) at 180 dpi	100 m/min	100 m/min
SX (Seiko) at 360 dpi	150 m/min	150 m/min
Maximum printing height		
HP (Hewlett Packard)	50 mm	50 mm
LX (Lexmark)	50 mm	50 mm
MX (Trident)	400 mm	400 mm
XR (Xaar)	248 mm	248 mm
SX (Seiko)	108 mm	108 mm
Maximum text length	1 m	3 m
Text field	yes	yes
Counter	yes	yes
Time display	yes	yes
Date field / date offset	yes	yes
Logo	yes	yes
Input of variables	yes	yes
Active fields	yes	yes
1D/2D code	yes	yes
Data transfer by USB stick	yes	yes
Ethernet	yes	yes
EIA232	yes	yes
Password protection	no	yes
Configurable inputs and outputs	yes	yes
<b>Technical data</b>		
Power supply direct	M12 socket 24 V DC	M12 socket 24 V DC
Power supply mains unit	100 to 240 V AC	100 to 240 V AC
Power consumption, maximum	100 W	100 W
Protection class	IP 30D	IP 30D
Ambient temperature	5 to 40 °C	5 to 40 °C
Relative humidity, non-condensing	10 to 90 %	10 to 90 %
Certification	CE	CE

Technical scale drawing

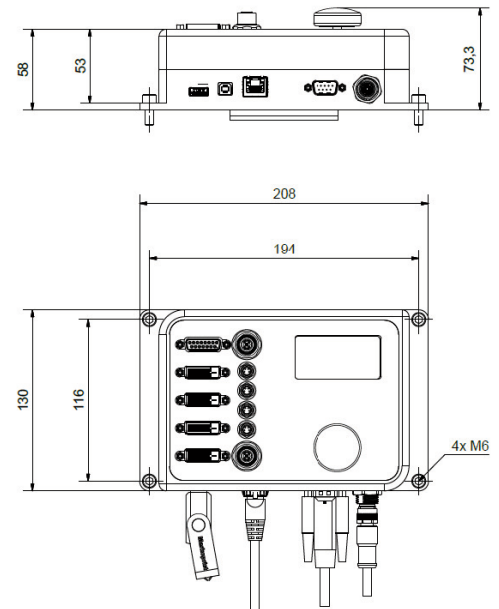

Technical changes reserved.